

# T20

Per escavatori 15.0-30.0 ton / For excavators 15.0-30.0 ton

TRINCIATRICI IDRAULICHE  
HYDRAULIC MULCHERS



T20 DF130	
T20 DF160	
T20 DF180	



**HF14**

Ø max 30 cm

di serie  
standard equipment









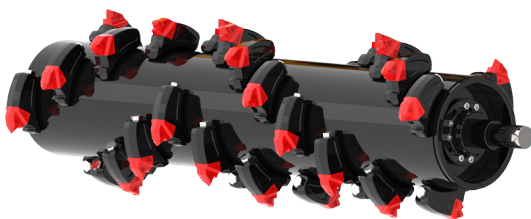
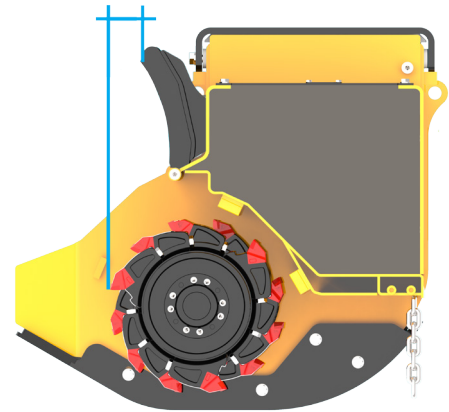

**HF15**

Ø max 25 cm

ROTORE AVANZATO  
FORWARD ROTOR



Modello Model	 (ton)	 (cm)	 (LxAxH cm)	 Kg	Cilindrata motore Motor displacement	 (L/min)	 bar (min-max)		Rotore Rotor	
T20 DF130	15.0-30.0	130	170x100x90	1.050	45-60-80	100-130 180	200-350	1 (55 mm)	elicoidale helical	36
T20 DF160	18.0-30.0	160	200x100x90	1.185	45-60-80	100-130 180	200-350	1 (55 mm)	elicoidale helical	42
T20 DF180	20.0-30.0	180	220x100x90	1.320	45-60-80	100-130 180	200-350	1 (55 mm)	elicoidale helical	54

#### CARATTERISTICHE TECNICHE E DOTAZIONI STANDARD

- DF rotore a denti fissi in widia o lama bonificata.
- Rotore elicoidale a 3 principi.
- Doppia fila contro lame pettine forgiate e temprate.
- Telaio antiusura molto resistente.
- Forma ad imbuto per una maggiore capacità di taglio.
- Trasmissione monocinghia dentata preallungata HTD ad alte prestazioni.
- Cofanatura interna a doppia cassa con intercapedine.
- Protezione carter cinghie.
- Cofano frontale idraulico, per una maggiore capacità di taglio.
- Supporti rotore interni con labirinto per la protezione dei cuscinetti dalle impurità.
- Cuscinetti rotore orientabili di prima qualità.
- Blocco valvole comprensivo di valvola prioritaria per regolazione della portata olio, antiurto (valvola di max pressione), anti-cavitazione.
- Motore a pistoni.
- Doppie catene posteriori per una maggiore protezione.
- Protezioni antinfortunistiche con catene a norma CE.

#### TECHNICAL FEATURES AND STANDARD EQUIPMENT

- DF Rotor with fixed teeth in widia or hardened blade.
- Helicoidal rotor with 3 screws.
- Forged and hardened counter-blades.
- Very hard anti-wear frame.
- Funnel-shaped frame for higher cutting capacity.
- Toothed high-performance belts transmission.
- Internally reinforced double-case body with interspace.
- Protective belts cover.
- Hydraulic hoods, fully openable for higher cutting capacity.
- Inside Rotor Supports with "labyrinth" for the protection of the bearings from the impurities.
- Adjustable bearings of 1st quality.
- Valves block complete with priority valve for adjusting oil flow, anti-shock valve (pressure relief valve), anti-cavitation.
- Piston motor.
- Dual row protection chains for better protection.
- Accident prevention chains protections according to EC directives.

#### ACCESSORI

- 1 - Attacco sella a perni 12.1-16.0 ton.
- 1 - Attacco sella a perni 16.1-25.0 ton.
- 2 - Kit tubi Lg. 2.5 metri.
- 3 - Motore a pistoni a portata variabile.

#### ACCESSORIES

- 1 - Mounting hitch & pins 12.1-16.0 ton.
- 1 - Mounting hitch & pins 16.1-25.0 ton.
- 2 - Hoses kit Lg. 2.5 meters.
- 3 - Piston motor, variable displacement.

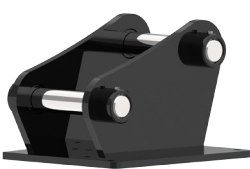

1

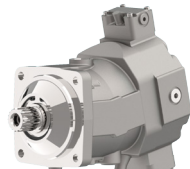

3

FIANCHI CON  
DOPPIA LAMIERA  
SIDES WITH  
DOUBLE SHEET

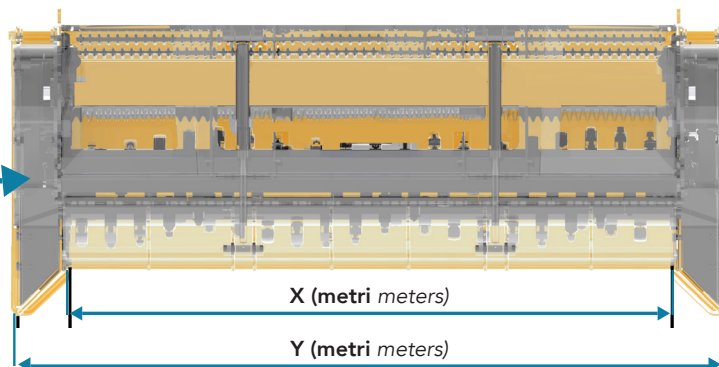

#### FORMA AD IMBUTO FUNNEL SHAPED

X	Y
1.30	1.60
1.60	1.90
1.80	2.10